

Betriebsanleitung für Axialkolben-Hydropumpen beachten

Ölzufuhr bei

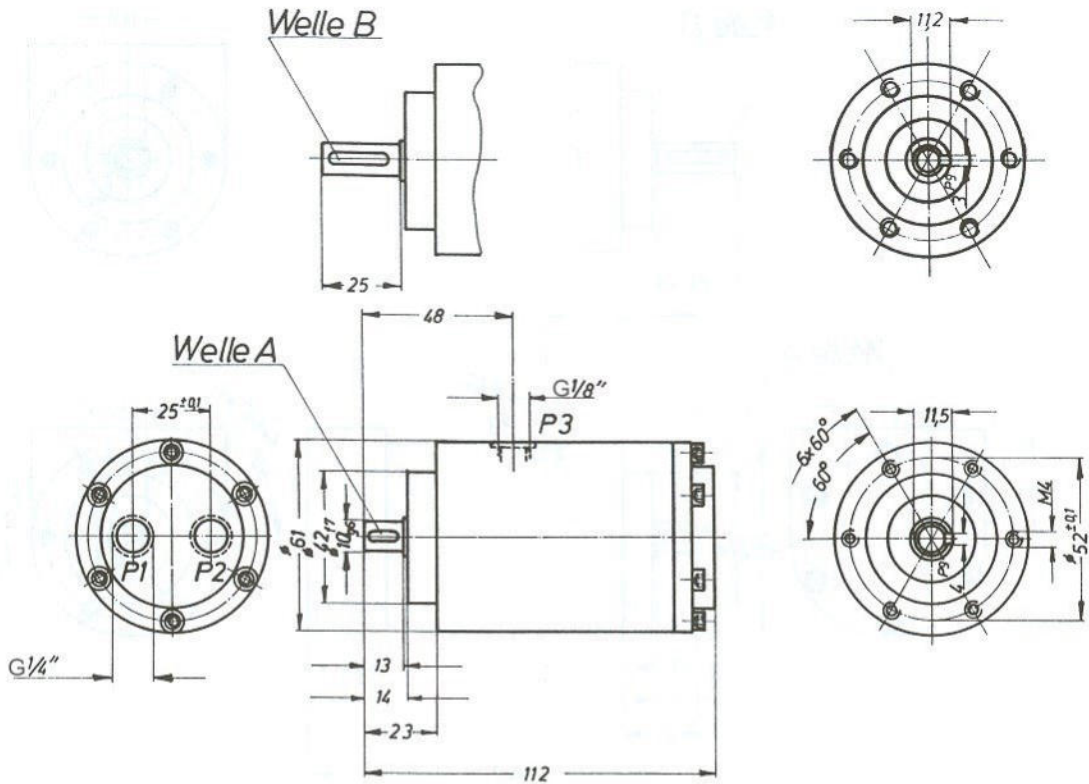
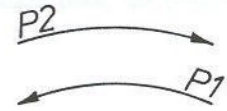

- Druckölschluß P1 G 1/4"
- Druckölschluß P2 G 1/4"
- Leckölschluß P3 G 1/8"
- P3 Lecköldruck max. 0,5 bar

Welle A oder B bei Bestellung angeben

Motor 1,1 kg

HMS	26	279	0,044	5000	100	140	5
HMS	37	353	0,055	3000	100	140	5
Motortype	q [cm <sup>3</sup> /U]	M [Nm/bar]	n <sub>max</sub> [min <sup>-1</sup> ]	P1 <sub>max</sub> P2 <sub>max</sub>	Σ P1 P2	P1 <sub>min</sub> P2 <sub>min</sub>	

Alle Drücke [P] in bar

**AXIALKOLBEN-MOTOR**

**SK251.1.1**



**MW Hydraulik GmbH**

Tel.: 0 61 88 / 8 12 91 Lange Hecke 7  
info@mw-hydraulik.de 63796 Kahl am Main